

e400 emitter



METALL+PLASTIC
Cleanroom Technology

M+P's compact emitter technology delivers the world's most efficient, clean, and cost-effective form of industrial process energy. The e400 emitter offers a sustainable alternative to conventional thermal or chemical based processes across a wide range of applications. Manufacturers can leverage this technology to reduce pollution, decrease energy consumption, and improve productivity.

The e400 leverages M+P's hermetically sealed emitter platform that enables a highly efficient, low energy elec-

tron beam in a modular, compact form factor. Designed for scalability and flexibility, the e400 can be used singly or in multiples depending on application requirements. With an operating voltage range of 80kV to 125kV, the e400 has the capability to deliver electron beam energy over 10cm through atmosphere or up to 130 microns deep into a typical polymer material. By bringing the power of electron beam processing directly to manufacturing lines, the e400 is a platform for energy efficient industrial processing for a wide range of applications.



COMPACT:

With no external vacuum pumps and a compact power system, M+P emitters are small enough to be integrated into a range of process machinery.

MODULAR:

Standard interface allows for straightforward integration and easy maintenance.

SCALABLE:

Designed to be used singly or in multiples.

SIMPLE:

Field replaceable modules require no on-site technicians or costly maintenance visits.

ADDRESSING A RANGE OF APPLICATIONS

M+P's low energy electron beam emitter technology offers unique advantages for a range of industrial applications including:

SURFACE STERILIZATION: High speed, room temperature sterilization of surfaces

CURING: VOC-free curing of inks, coatings and adhesives on any substrate

MATERIALS ENGINEERING: Surface modification and crosslinking of polymer materials

AIR TREATMENT: Air sterilization and pollution abatement



SIMPLIFYING SYSTEM INTEGRATION

Designed for direct integration into third-party machinery, M+P brings the power of electron beams to the manufacturing process. With standardized product interfaces and design consulting services, M+P works closely with partners to design complete electron beam enabled solutions. A growing list of equipment manufacturers are choosing to offer electron beam enabled versions of their equipment.

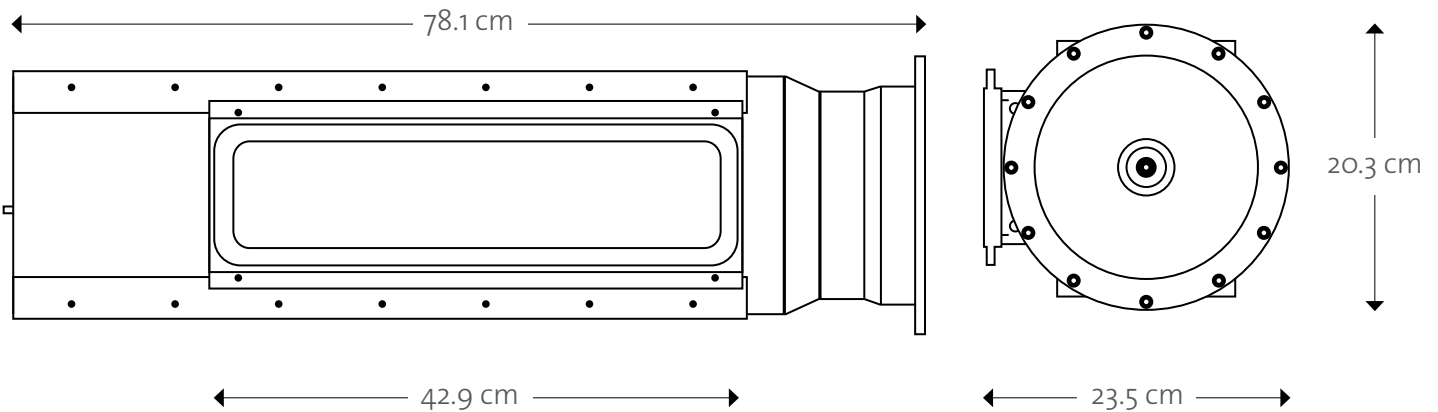

Operating Voltage	80kV to 125kV
Process Width	368 mm
Beam Output (at full power)	1830 kGy m/min
Power Consumption (typical range)	3-6 kW
Weight	20 kg

METALL + PLASTIC offers proven solutions for in-line electron beam sterilization for pharmaceutical, medical device, food, and beverage packaging applications. For more informations: www.metall-plastic.de

GERMANY

METALL + PLASTIC GmbH, Bodmaner Straße 2, 78315 Radolfzell-Stahringen
Phone +49 77 38-92 80 - 0, Fax +49 77 38-92 80 - 10, info@metall-plastic.de

Member of

OPTIMA